



INSTALLATION INSTRUCTIONS

LHZ-04 BASS PREAMP (REV 4.1)

PREAMP CONNECTION VIA DUPOINT™ COMPATIBLE PIN HEADERS

The LHZ-04 features pin headers that are compatible with modular EMG controls which makes this preamp easy to install with minimal soldering. The installation kit also ships with several connectors with flying leads that allow this preamp to be connected easily to traditional soldered volume potentiometers and barrel jacks.

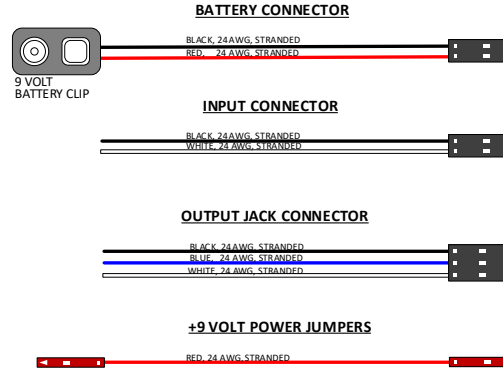

While pin headers make installation easy, it is very important to adhere to the wiring diagrams in this manual! The connectors are NOT keyed, so reversing the connections will result in polarity reversal that will result in no sound being produced.

ABOUT THE LHZ-04

The LHZ-04 is a compact PCB (Printed Circuit Board) employing the same vintage HazLabs® preamp circuit design as used in the 80's Spector® NS2 bass guitars..

The LHZ-04 is a compact PCB measuring 25.4mm X 41mm (1" X 1-5/8") featuring DuPont™ compatible solderless pin headers to connect BATTERY power, receive INPUT from existing volume pots, and send the OUTPUT to the barrel jack. There are two dedicated POWER pins to provide positive voltage to pickups and active controls. The compact design and included connectors make the LHZ easy to install in almost any bass guitar and supports a wide variety installation wiring customization.

Every LHZ-04 is fully tested before being shipped, assuring the unit is ready for use.

BYOP: BRING YOUR OWN POTS!

The LHZ preamp is designed to receive input from the existing volume (or volume and blend) pots. This is by design: the LHZ-04 works with any pickups (active, passive, single coil, humbucker, split coil) from any manufacturer.

Pickup manufacturers specify the volume and blend pot values that are recommended for best performance. We do not provide volume and blend pots so users have the flexibility to configure their pickup and volume controls for optimal performance and comfort. You select the pickups and pots you need; the LHZ will take the output from there and make it awesome!

PREPARING FOR INSTALLATION

Before starting, make sure you have everything ready. For most users this means having the following components on hand:

- The LHZ-04 preamp (includes cables and mounting tape)
- User-provided pickups
- User-provided volume pots (or volume & blend pots)
- User-provided output jack with 3 pins (Switchcraft 152b or similar)
- Soldering iron and solder (for installations that require soldering)

While the pin headers allow the LHZ-04 to be connected to modular EMG control systems without soldering, most installations require soldering wires to the output barrel jack. If you wish to avoid soldering your existing barrel jack, LHZ does sell prewired Switchcraft 152 barrel jacks as an additional component that will plug directly into the LHZ preamp.

If your installation requires soldering, we **HIGHLY RECOMMEND** that you cover the back of your instrument to protect the finish from potential damage. Soldering is generally a very clean operation, but it does often result in rosin (found in the core of solder) to splatter. Covering your instrument finish will protect it and save cleanup time later.

RECOMMENDED INSTALLATIONS STEPS

This guide contains multiple wiring diagrams and variations that cover the most common installation options. Once you decide on the diagram to use, the following general steps are recommended to reduce potential errors and risk of damaging the finish on your instrument.

Instructions assume that the existing volume (or volume and blend) pots will remain in the bass and be connected to the LHZ.

STEP 1: REMOVE THE EXISTING PREAMP

- **Take pictures** of your existing wiring and note where the volume, blend, bass, and treble pots are currently located. *Take multiple photos from different angles to ensure you can see all the wiring and connections.*
- **Disconnect** (cut or unplug) the three wires between the **output jack** and existing preamp.
- **Disconnect** (cut or unplug) the two wires between the **battery** and existing preamp.
- **Disconnect** (cut or unplug) the two wires between the **volume pot** and existing preamp.
- Remove the original preamp and its Bass and Treble potentiometers.

STEP 2: SOLDER QUICK DISCONNECT CABLES TO COMPONENTS

The preamp ships with cables for connecting the LHZ preamp to components that do NOT have DuPont style quick-disconnect pins.

- TRADITIONAL SOLDERED VOLUME POTENTIOMETERS:
 - Solder wires from the 2-pin connector to the volume pot. This is normally just two wires (BLACK = GROUND and RED or WHITE = SIGNAL) that connect the output of the last volume pot to the **INPUT** connector on the LHZ.
- OUTPUT BARREL JACK:
 - Solder wires from the 3-pin connector to the barrel jack. This connector will go to the **OUTPUT** connector on the LHZ. **NOTE:** Refer to the install diagram regarding the 3 connections on the Switchcraft 152B jack:
 - T = Tip (This is the output signal.)
 - R = Ring (Connects ground to power the preamp when a jack is plugged in.)
 - S = Sleeve (Signal Ground and battery negative.)
- +9 VOLT POWER TO SOLDERED ACTIVE PICKUPS:
 - Cut an end off one of the 1-pin jumpers to solder the wire to the RED wire from active pickups. This will connect to the + **PWR** pin header to provide battery power to the pickups.
- BATTERY POWER FROM SEPARATE BATTERY CAVITY
 - Cut the battery clip off the included power connector
 - Solder the RED and BLACK wires to the RED & BLACK wires from the battery compartment
 - Plug the 2-pin connector into the LHZ **BAT+** and **BAT-** pin header

STEP 3: INSTALL THE LHZ-04 PREAMP

- Mount all potentiometers in the bass in their desired locations.
- Connect the output barrel jack to **OUTPUT** pins located on the right side of the LHZ preamp.
*(NOTE: Make sure the **TIP** wire is connected to the **T** pin!)*
- Connect the output from the volume (or volume & blend) pots to the **IN** pins located on the left side of the LHZ preamp.
- For active pickups, or EMG controls that need + battery power, connect to the **PWR+** pins located on the left side of the LHZ preamp.
- Connect battery power to the **BAT+** and **BAT-** pins located on the top left of the LHZ preamp.
Polarity is critical: note the location of Red positive connection on the diagram!
- Secure the LHZ against the cavity wall using the included non-conductive foam tape.
- Secure the battery to ensure it is not loose within the cavity. (Most basses have a strap are compartment for this purpose.)

IMPORTANT: The 3M VHB tape shipped with the preamp protects the circuit board connections from making direct contact with the conductive cavity walls. If this tape is removed or damaged, carefully inspect the installation to ensure the back side of the LHZ preamp does not make direct contact with the conductive foil or paint used on the cavity wall!

USAGE

If you are looking for that classic 80's NS2 HazLabs® tone, then you'll just want to set both Bass and Treble near maximum (referred to as being "dimed"), set the blend halfway so both the P and J pickups are on, and turn the volume knob all the way up.

Playing with a light touch will give you a full articulate tone with a tight, but deep low end. Digging in hard with fingers or a pick will push the LHZ-04 to result in that unique "Haz" tone that slightly compresses and adds overtones to transients that make them very articulate without being overbearing.

UNPLUG WHEN NOT BEING USED

The LHZ-04 preamp requires very little current, so a typical 9-volt alkaline battery can last a year or more with normal use. The preamp is powered whenever a guitar cord is plugged in which enables power to the preamp circuit. This is a standard design used for almost all pre-amps.

To maximize battery life, unplug the bass when not being used.

We recommend Duracell Alkaline batteries, and replacing them every 6 months whether needed or not.

ACTIVE PICKUPS: DUAL VOLUME (SOLDERED)

EMG WIRING HARNESS COLORS:

BLACK: Negative
 RED: Positive 9 or 18 volts
 WHITE: Output

NOTE: Wiring diagram shows GREY wires instead of WHITE for printing legibility

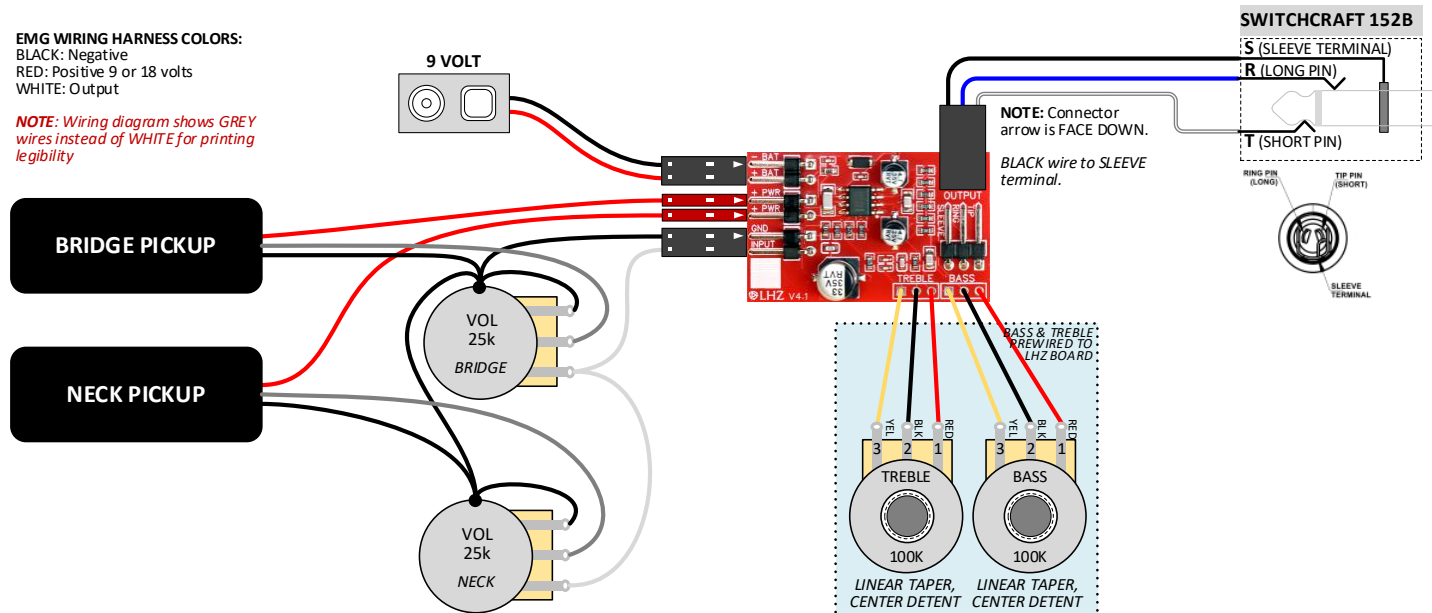

ACTIVE PICKUPS: DUAL VOLUME (MODULAR)

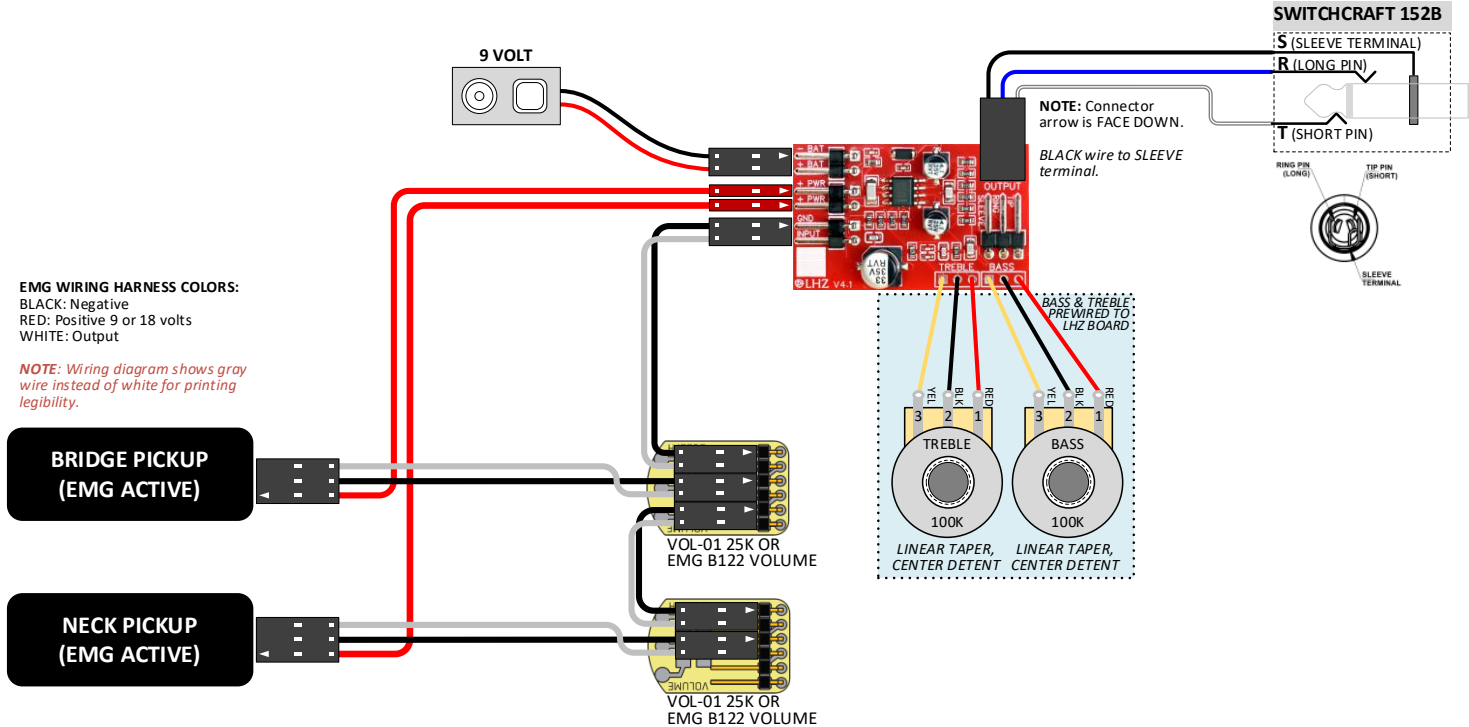

ACTIVE PICKUPS: BLEND & VOLUME (MODULAR)

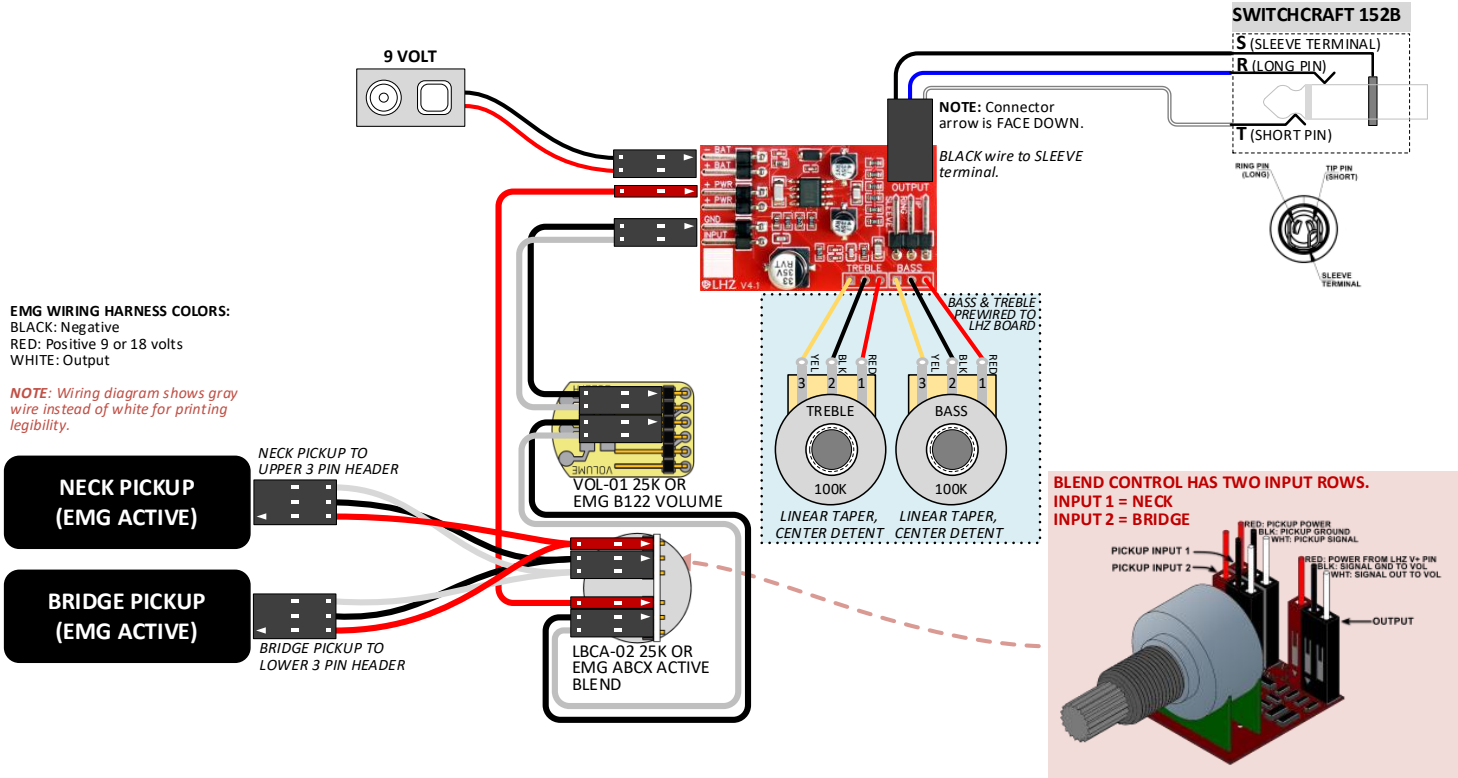

ACTIVE PICKUPS: TW CONTROLS (MODULAR)

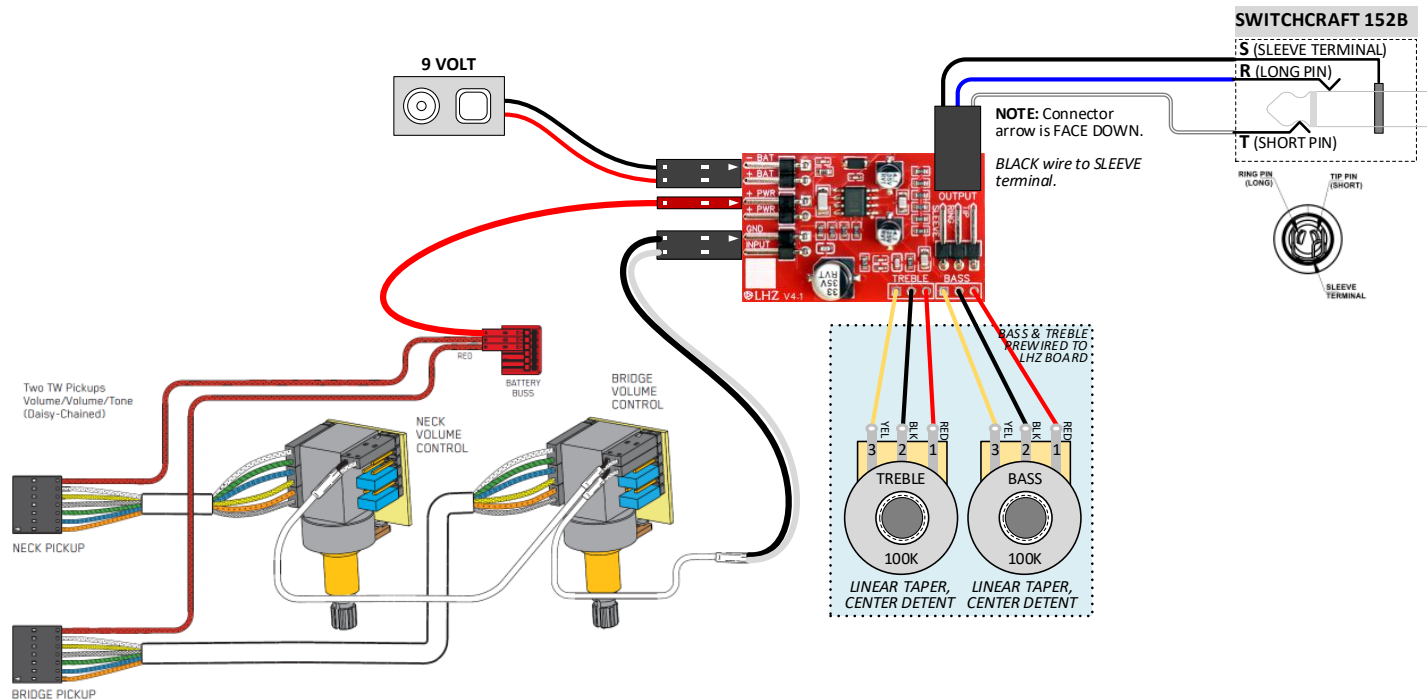

PASSIVE PICKUPS: DUAL VOLUME (SOLDERED)

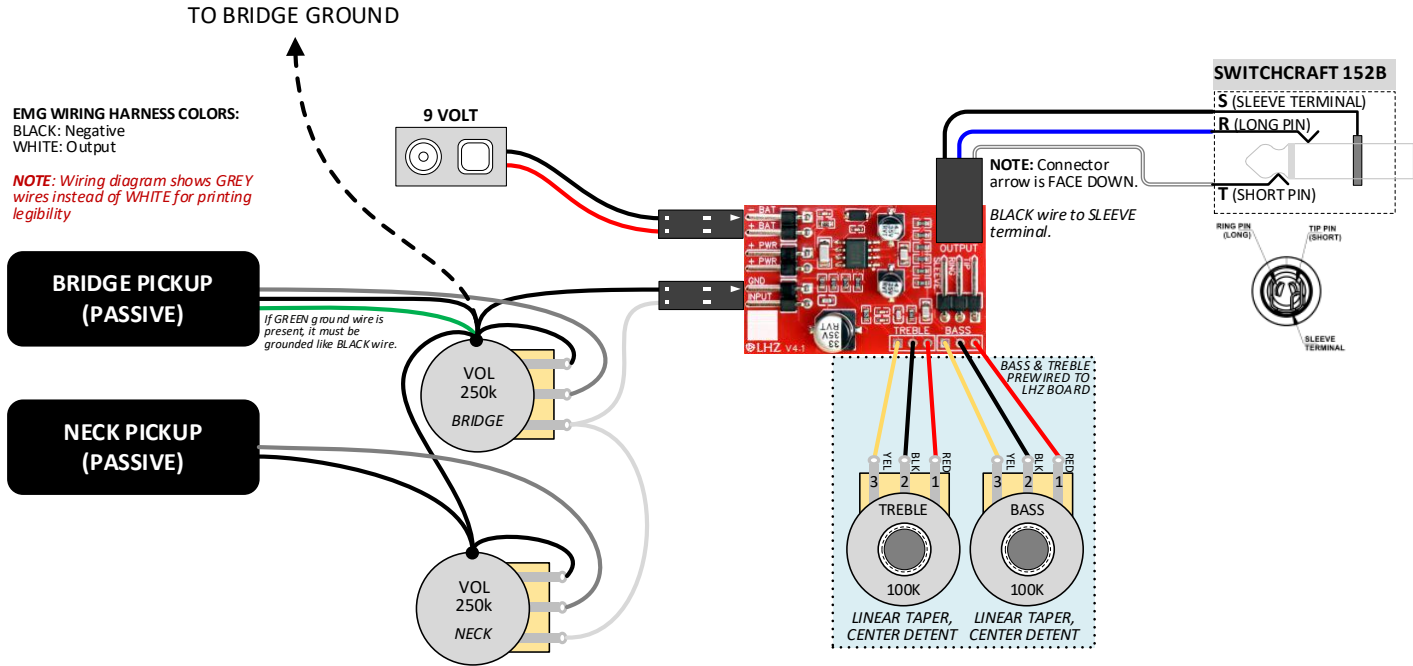

PASSIVE PICKUPS: BLEND & VOLUME (SOLDERED)

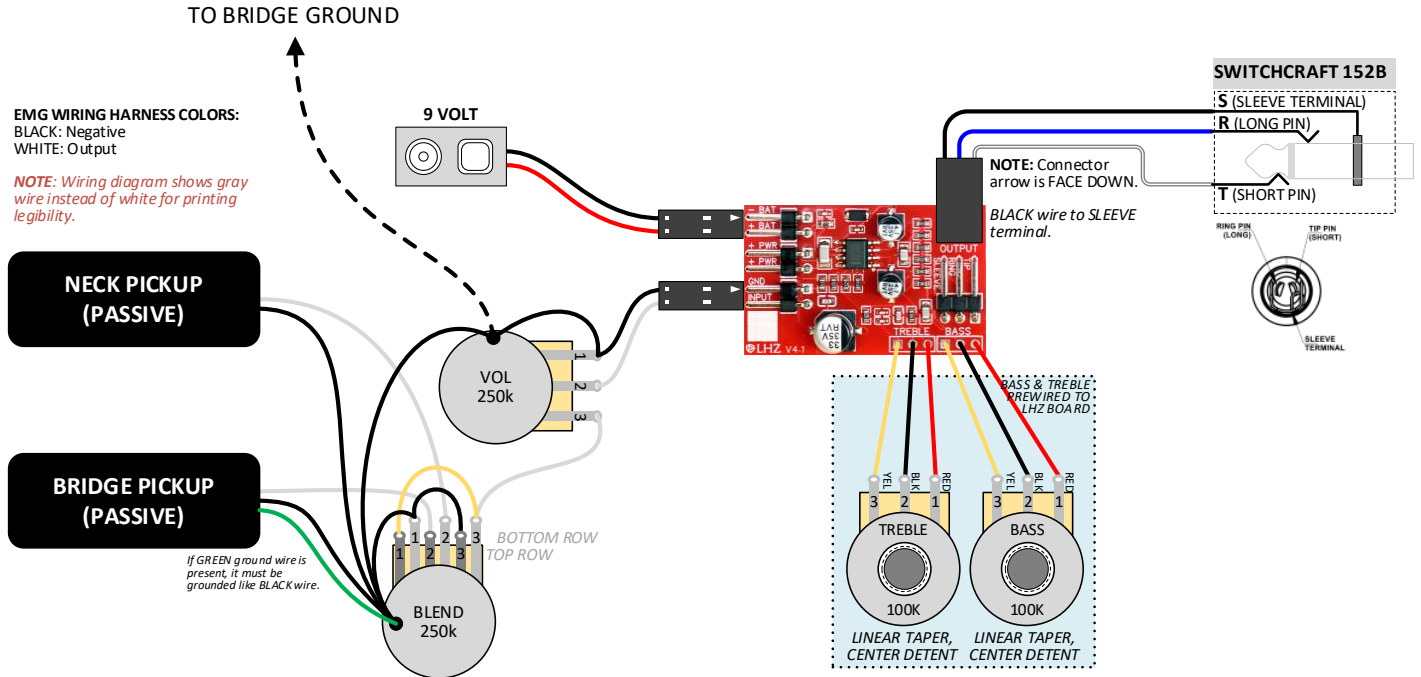

PASSIVE PICKUPS: DUAL VOLUME (MODULAR)

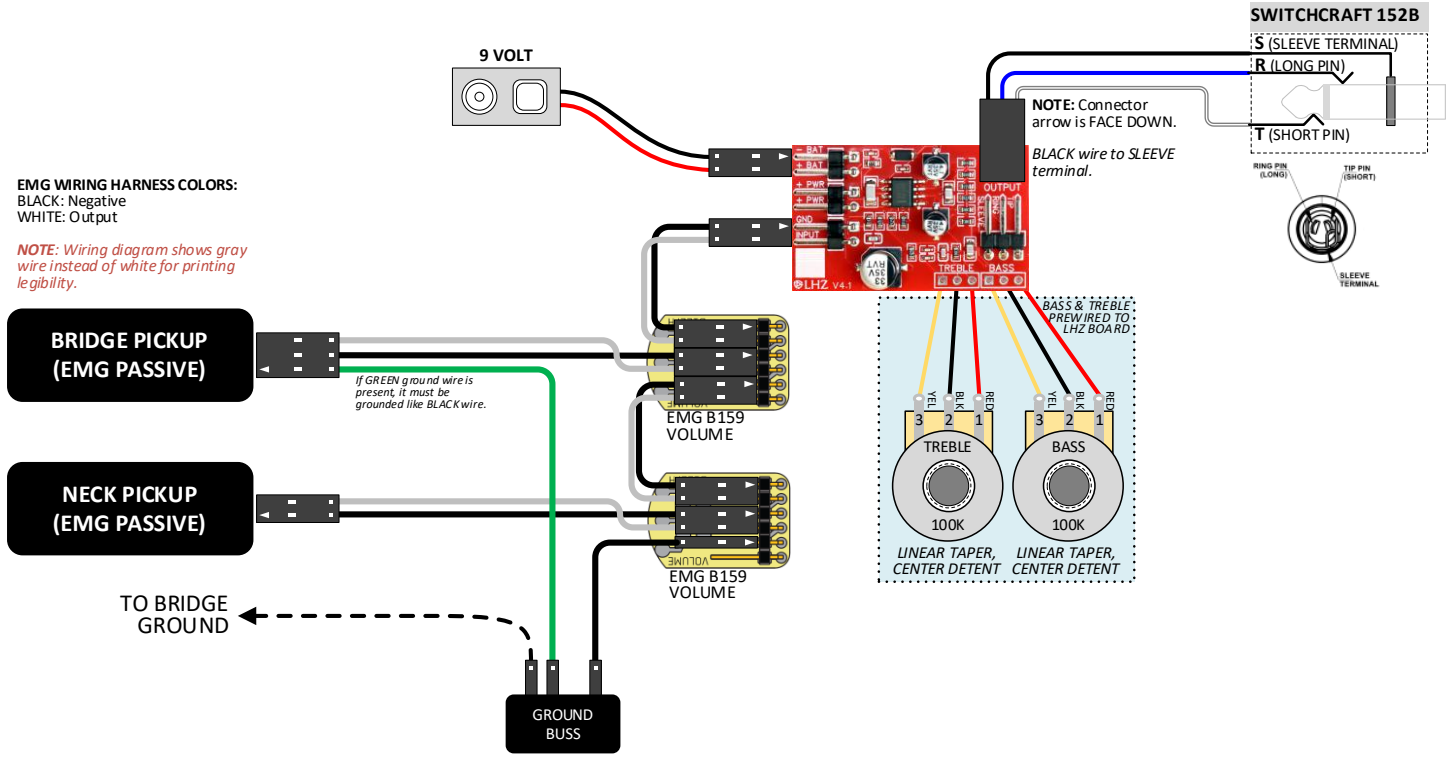

PASSIVE PICKUPS: BLEND & VOLUME (EMG MODULAR)

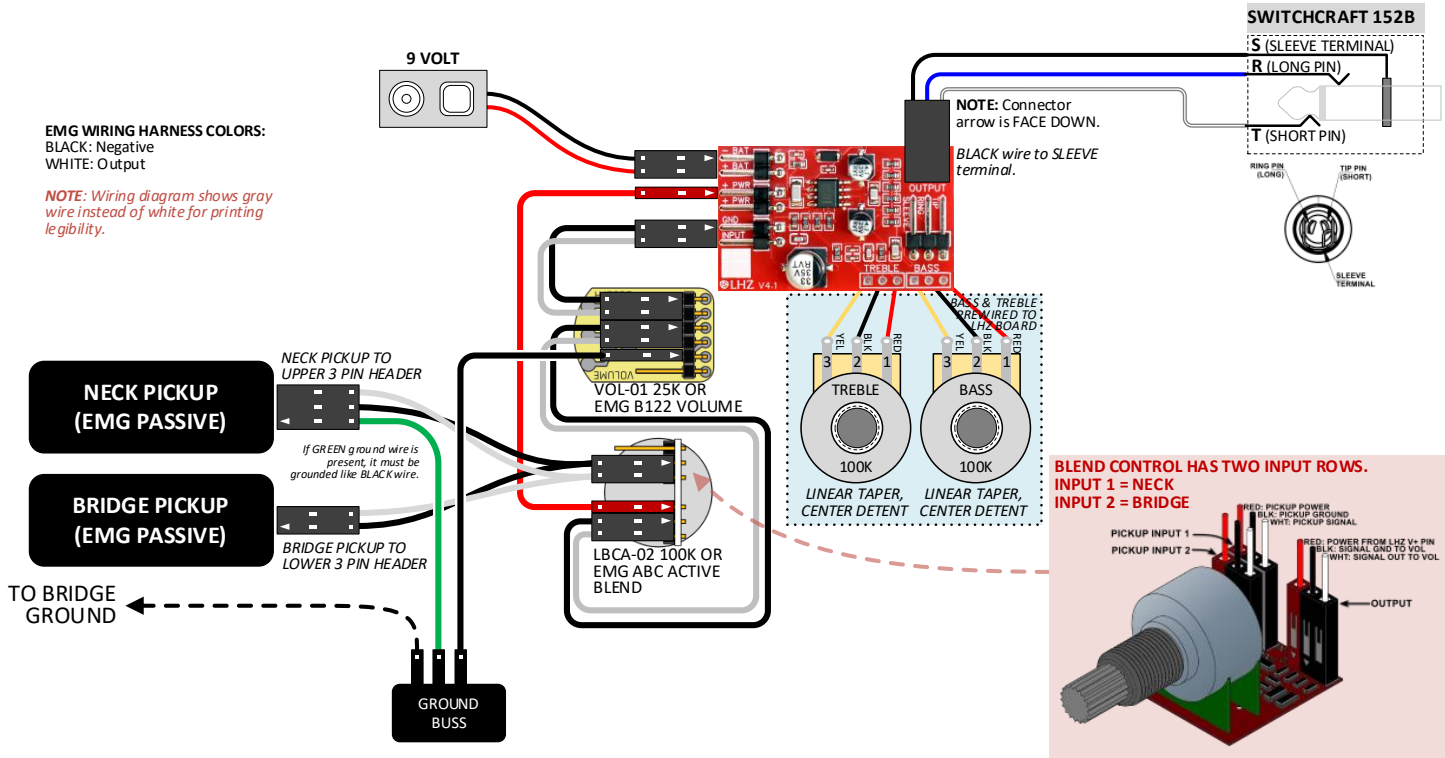

HUMBUCKER PICKUPS: DUAL VOLUME (SOLDERED)

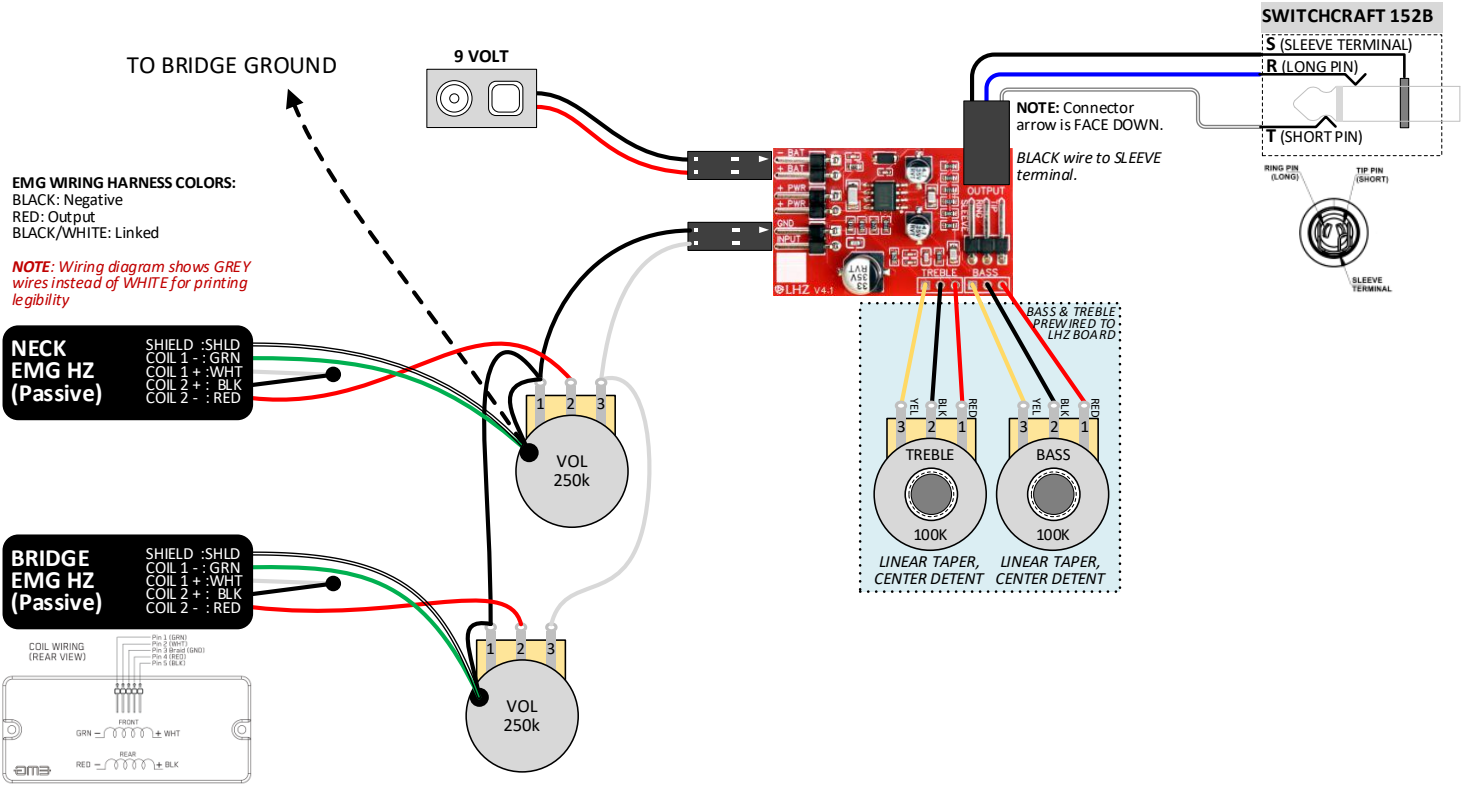

HUMBUCKER PICKUPS: BLEND & VOLUME (SOLDERED)

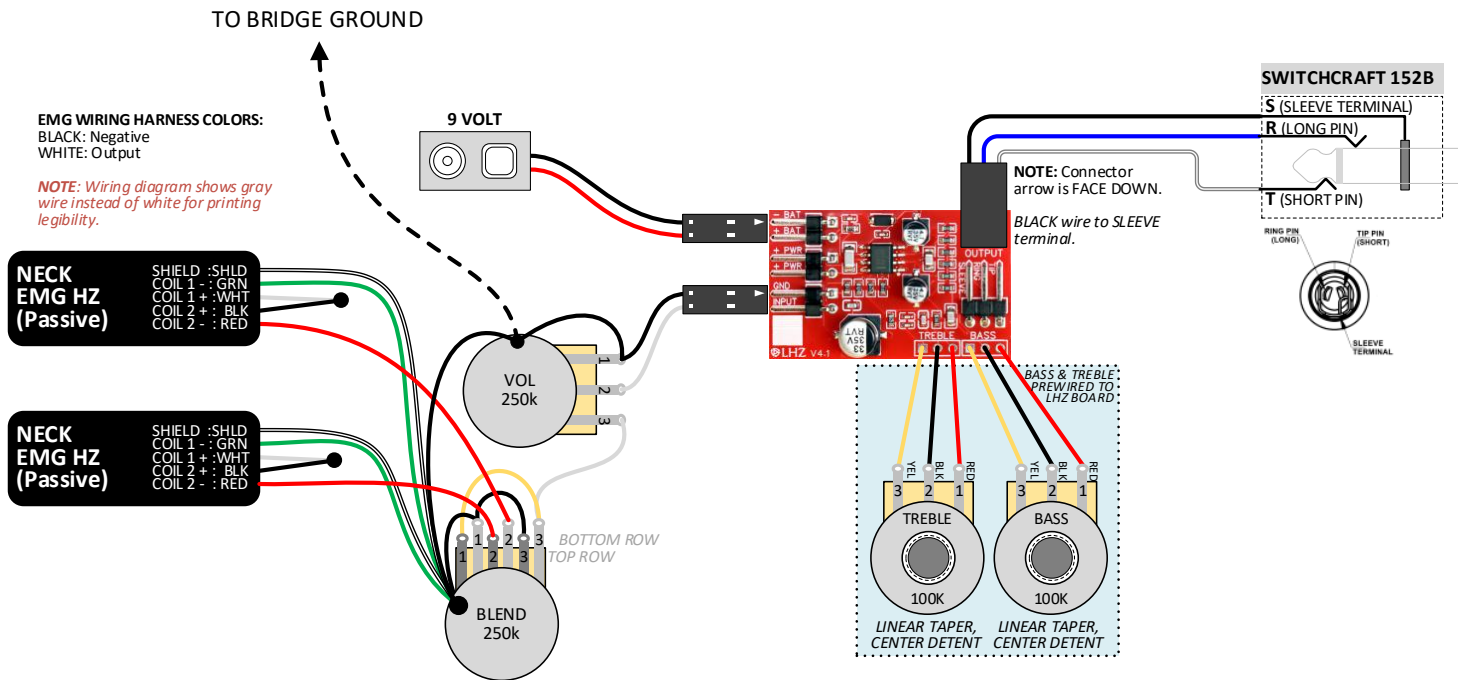

HUMBUCKER PICKUPS: DUAL VOLUME (MODULAR)

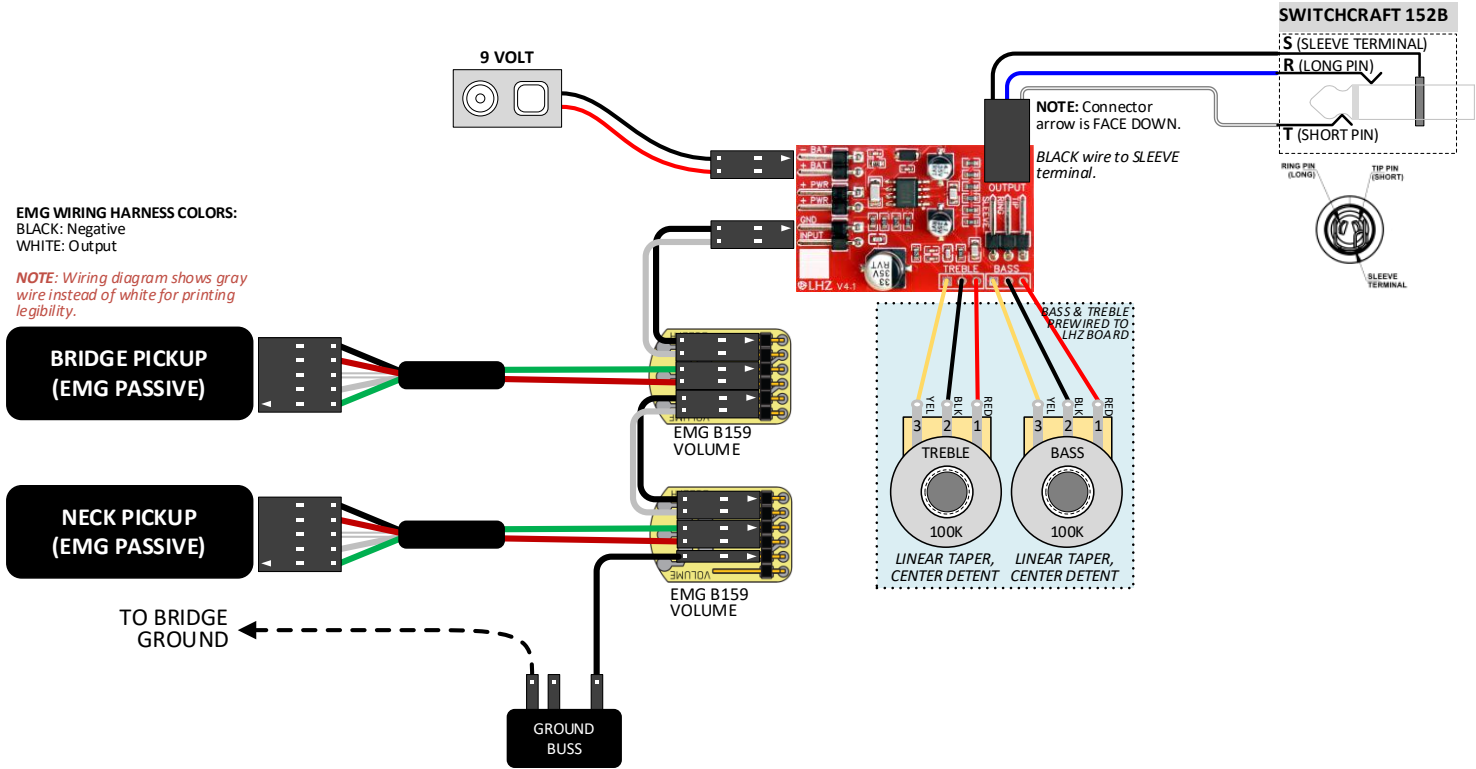

HUMBUCKER PICKUPS: BLEND & VOLUME (MODULAR)

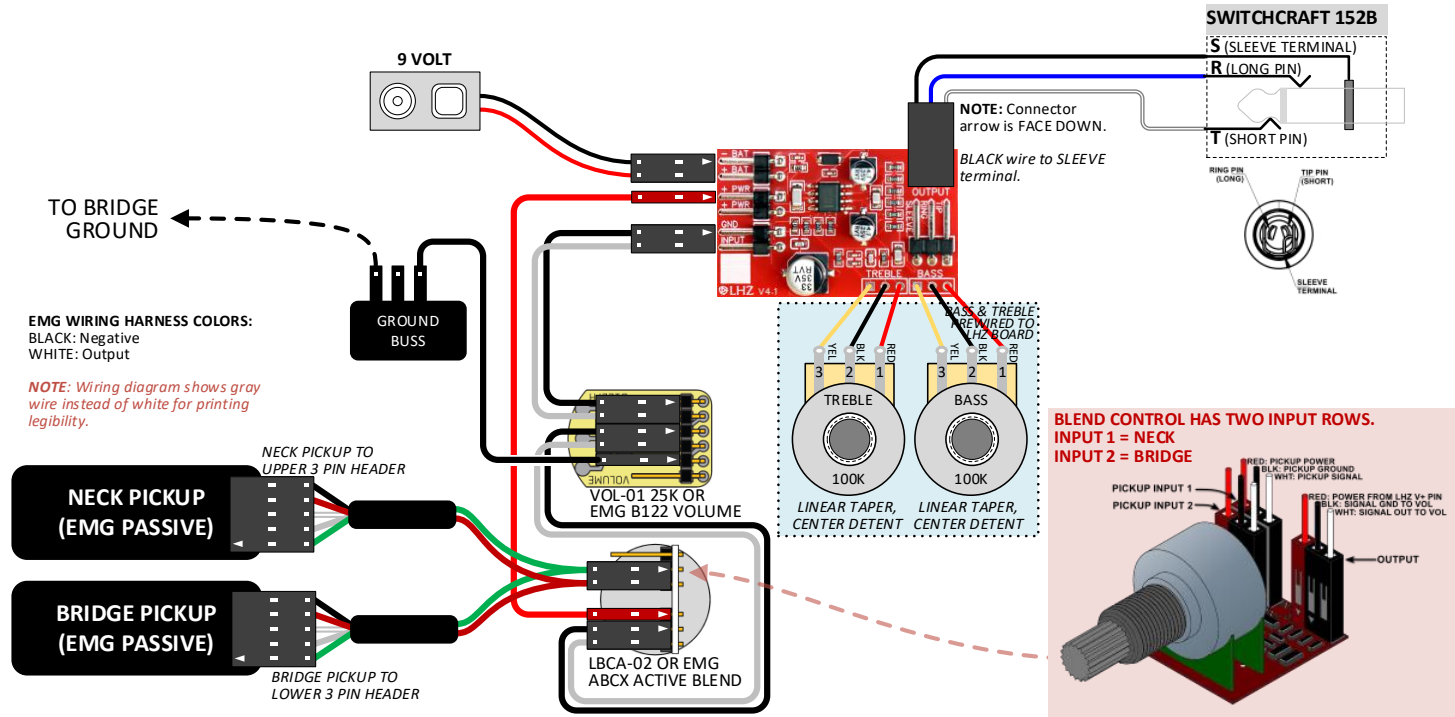

NORDSTRAND HUMBUCKER PICKUPS: DUAL VOLUME (SOLDERED)

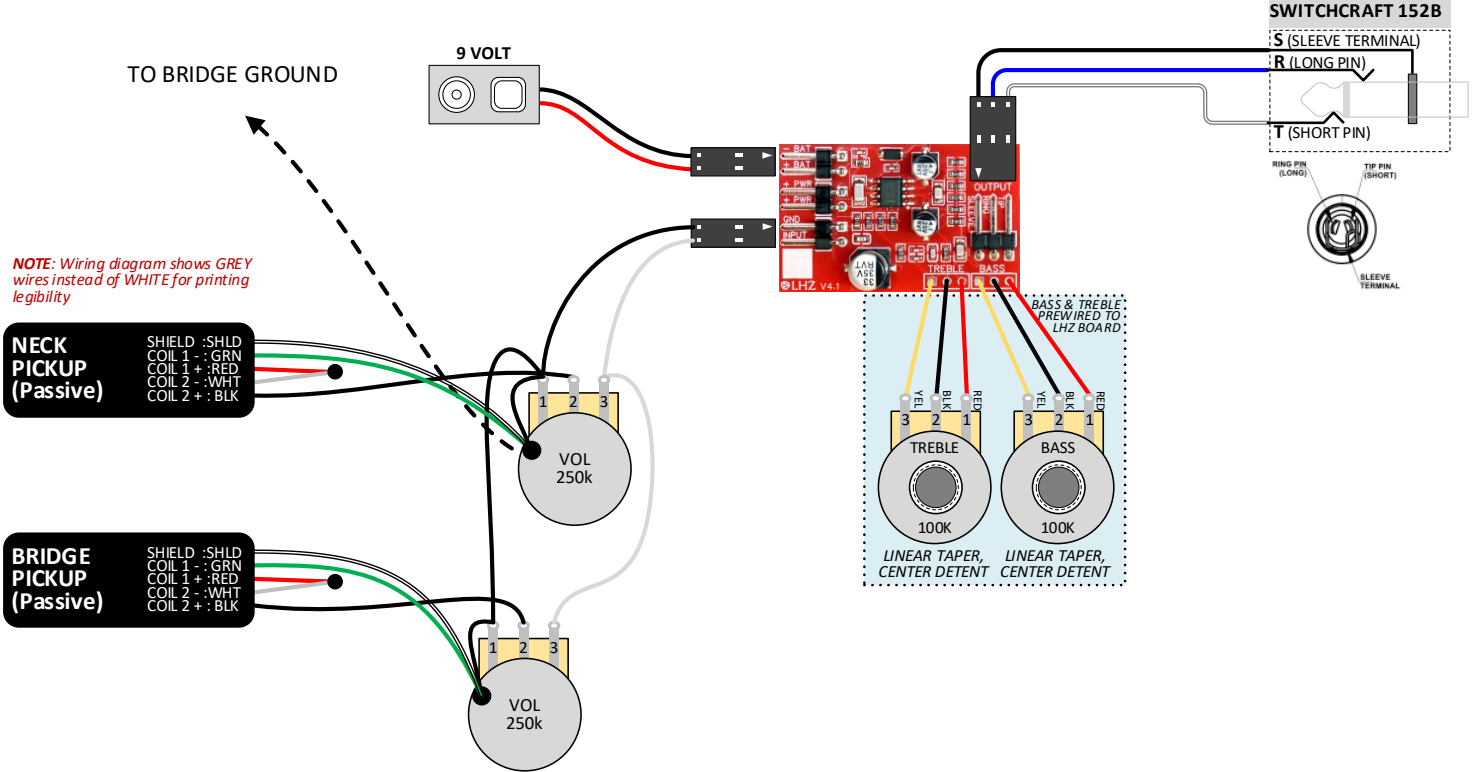

TRS JACK WIRING AND OPERATION

It is important to positively identify the TRS pins on your output jack before wiring as the order may vary between jack styles and manufacturers. While a guitar cord has only 2 conductors, a 3-conductor TRS jack allows the guitar cord to also act as a power switch for the preamp.

When a standard guitar cord is plugged into a 3-conductor jack, the SLEEVE and RING connectors both contact the SLEEVE segment. This allows the R and S connectors to act as a power switch for the preamp: when a guitar cord is plugged in, the negative ground from the Sleeve connector is passed through the Ring connector to power the preamp. The output signal of the preamp goes to the Tip connector.

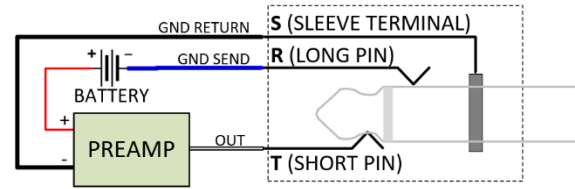

COMMON CONFIGURATIONS

Spector basses use the SWITCHCRAFT 152B Barrel Jack. The Tip is the short spring, the Ring is the long spring, and the Sleeve is the long cable clamp. Traditional 3-conductor jacks will typically have three separate connectors in a different orientation as shown below:

SWITCHCRAFT 152B 3-CONDUCTOR STEREO BARREL JACK

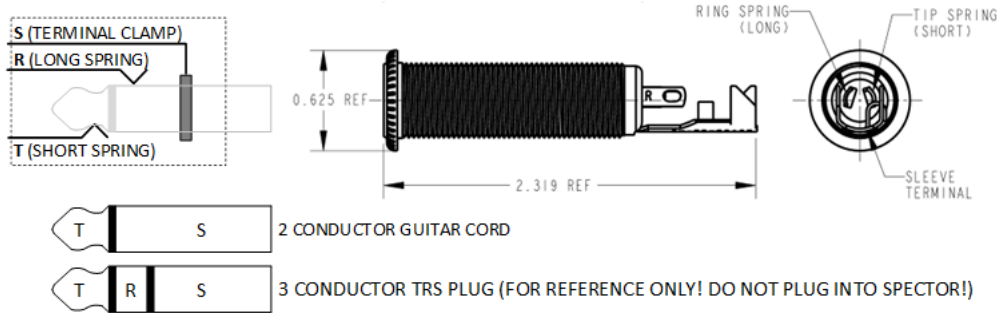

TRADITIONAL 3-CONDUCTOR JACK

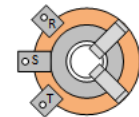

IMPORTANT: Note that the connection of the solder tabs are in a different order! Always identify which are the T, R, and S connections before use.

WIRING NOTES

Every LHZ-04 is 100% tested before being shipped to ensure the preamp is fully functional and ready for use.

As with any electronic devices designed for custom wiring, there is opportunity for installation errors that can adversely impact the operation of the preamp, and in certain cases permanently damage the preamp, pickups, or other components.

The most important considerations are power connections, so pay careful attention to the wiring diagrams. Specifically:

- Positive (+) and Negative (-) battery connection must be correct.
- The TIP of the output jack must be connected to the T pad on the OUTPUT connector.
- Use only a standard mono instrument cable (not a Stereo or TRS cable) to connect your bass to an amp.
- Make sure preamp circuit board does not make direct contact with exposed wires, metal components, or conductive paint or foil within the cavity. We ship double-sided non-conductive foam tape to secure the preamp to the cavity wall.

TROUBLESHOOTING

EQ OR VOLUME CONTROLS WORK BACKWARDS

- Reverse pins 1 and 3 of the pot to reverse how the control operates.

NO SOUND / RAPID BATTERY DRAIN

- Make sure Positive (+) battery lead is connected to **BAT+** on the LHZ.
- Verify active pickups RED leads go to the **PWR+** connections and BLACK leads go to a **GND** connection.
- Verify OUTPUT connections are correct per diagrams.

NO SOUND

- Make sure you have a standard MONO instrument cable plugged into the output jack. The Sleeve (S) and Ring (R) connectors both make contact with the Sleeve of a standard instrument cable, which completes the circuit and allows power to flow to the preamp.
- Verify connections are fully seated. (Inexpensive connectors from Amazon are prone to poor connections.)
- Make sure underside of LHZ-04 is insulated and not making direct contact with metal components or conductive cavity walls.

SUPPORT

This preamp is designed for flexibility and intended for installation by users with basic electronics knowledge. This installation manual covers the most common installation scenarios; however it is possible to connect components in a wide variety of ways. The schematic is included to help advanced users understand how they can determine their own installation variations.

If you have a problem installing or using the LHZ-04 by following the standard installation wiring diagrams, please email us with your questions. While we typically reply within 1 – 2 hours, please be aware it may take several hours to reply.

All units are tested before shipment. In the unlikely event that you have unit that does not work, we will make every attempt to resolve your installation. We cannot offer refunds or replacements for devices that have been damaged due to improper installation or exposure to excess voltages.

Support Email: Sales@LHZpreamps.com

TRADEMARK DISCLAIMER

All products and company names are trademarks™ or registered® trademarks of their respective holders. Use of the does not imply any affiliation with, or endorsement by, them.

Any product names, logos, brands, and other trademarks or images referred to within this manual are the property of their respective trademark holders. These trademark holders are not affiliated with LRW Media or our products.

PAGE INTENTIONALLY LEFT BLANK